



SUPERIOR LOADING DOCK SYSTEMS

Nordock® Loading Dock Systems

PRODUCT OVERVIEW

Facilitate the loading and unloading of your goods with Nordock's® reliable, engineered loading dock system for your warehouse. Our full line of loading dock and materials handling systems bridges the gap and height difference between the dock and transport, operated via mechanical, hydraulic or air powered systems.

Optimise the efficiency of your supply chain and productivity of your warehouse from entry to exit with this range of innovative dock levelers that is made safer, more durable and functional to meet specific industry needs.

TYPES OF DOCK LEVELERS

- Air Powered Dock Levelers
- Hydraulic Dock Levelers
- Climate Control Dock Levelers
- Flex-Lip® Dock Levelers
- Mechanical® Dock Levelers
- Edge Mount Dock Levelers

NORDOCK® AIR POWERED DOCK LEVELERS

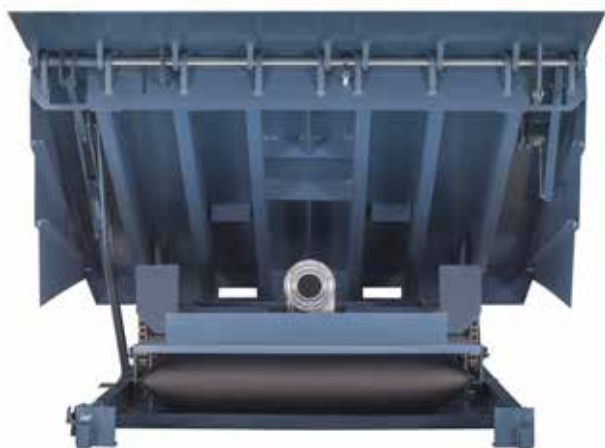

THE EVOLUTION OF AIR BAG TECHNOLOGY

NORDOCK® advances loading dock efficiency with patented 'Next Generation Air™' technology that is truly revolutionary. AIRDOCK® levelers are easy to install, operated by push button, and come with unmatched strength, standard features and comprehensive warranties that set a higher standard of excellence.

NORDOCK® air-powered dock levelers are tested and proven in thousands of busy loading docks.

KEY FEATURES

- 1 AIRDOCK® SUPER-DUTY™ SERIES**
With 60,000 lb. capacity this is the toughest air powered leveler ever built.
- 3 PULL ACTION™ LIFTING SYSTEM**
The patented Pull-Action™ lifting system maximizes efficiency by using the entire power of the bag to lift the deck.

- 2 AUTO-DESCENT LIP™ EXTENSION**
The Auto-Descent Lip™ extension uses the natural weight of the deck to activate the lip.

- 4 PROTECTED SINGLE-CHAMBER™ BALANCED AIR BAG DESIGN**
The reinforced PVC coated single chamber balanced air bag is protected over 99% of the time.



Nordock® Loading Dock Systems

- 5 AIRDOCK® INDUSTRIAL™ SERIES**
The smart choice for the most demanding loading dock applications.

- 6 BARRIER™ SERIES**
Stay-Put safety barrier lip prevents accidental fall off of dock and is available on air and hydraulic powered levelers.

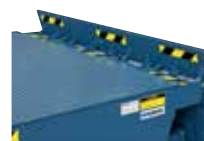

NORDOCK® HYDRAULIC DOCK LEVELERS



NO COMPROMISE CONSTRUCTION FOR SMOOTH EASY OPERATION

NORDOCK® hydraulic levelers are the ultimate in strength, convenience and day-to-day reliability. The power unit is a frame mounted integral assembly fully tested and oil filled. The motor is a totally enclosed non-ventilated type available in all voltages. Regenerative hydraulic cylinders are a heavy-duty design with polished chrome rods, guide bearings and high-pressure seals.

KEY FEATURES

- 1 HYDRAULIC SUPER-DUTY™ SERIES**
The Super-Duty™ Series levelers are built to handle the really tough applications found in the paper, steel and heavy manufacturing industries. Available up to 160,000 lb. capacity.
- 2 HEAVY-DUTY™ SERIES**
A full featured hydraulic dock leveler with industry leading 20-Year front and rear hinge warranties.
- 3 DUAL-DUTY™ SERIES**
The patented Dual-Duty™ hydraulic system utilizes a single hydraulic cylinder to lift the deck and lip.
- 4 PERFORMA™ SERIES**
Hydraulic powered leveler with patent pending Auto-Descent lip extension. Available up to 50,000 lb. capacity.
- 5 XW SERIES**
This unique dock leveler allows full access below floor for wide loads that simply cannot be managed with conventional levelers. The hydraulic powered steel face dock bumpers operate automatically to clear the way as the deck descends.
- 6 PATENTED LIPLUG AND HEADER PLATE**
The deck plate, lip plate, beam sections and lugs are constructed of minimum 50-55,000 PSI yield material.
- 7 CONTINUOUS REAR HINGE**
The continuous rear hinge provides side-to-side tilt with no pinch point.

Nordock® Loading Dock Systems

CLIMATE CONTROL LEVELERS



NORDOCK® TELESCOPING LIP™ LEVELER

An energy efficient alternative to vertical storing levelers. The Telescoping Lip™ dock leveler fully retracts so the insulated dock doors can store against the pit floor. Unlike rotating lip designs, the fully hydraulic powered deck and telescoping lip allow for precise positioning onto the trailer bed for safer loading and prevention of product and forklift damage.

KEY FEATURES

1 INCREASE FLOOR SPACE

Storing horizontal saves money by eliminating the need for costly bollards, conduits and stanchions and opens up valuable floor space.

3 EASY OPERATING CONTROLS

Integrated controls on special mounting stanchion.



2 TLH SINGLE DOCK LEVELER

ATL restraint, inflatable header seal, and steel face bumpers

4 VERTICAL MAINTENANCE MODE

The TLH Series opens to full vertical mode for routine maintenance and easy pit clean-out.

5 COLDSTORAGE™ HYDRAULIC VERTICAL STORING DOCK LEVELER

The NORDOCK® COLDSTORAGE™ series of vertical storing dock levelers provide maximum energy efficiency, cleanliness, and are ideal for climate controlled facilities in the food, beverage and pharmaceutical industries.

FLEX-LIP DOCK LEVELERS



THE SMOOTHEST TRANSITION FROM THE TRUCK BED TO THE LOADING DOCK

The NORDOCK® FLEX-LIP™ is controlled by a revolutionary parallelogram linkage system that extends the lip automatically as the leveler deck deploys, and maintains the lip horizontally in all positions, even when below dock loading.

The FLEX-LIP™ reduces the risk of grounding low clearance pallet truck and forklifts saving on equipment maintenance, fragile goods damage and personnel injuries.

Nordock® Loading Dock Systems

KEY FEATURES

1 PATENTED PARALLELOGRAM LINKAGE SYSTEM

Designed to provide level loading throughout its entire working range.

3 EXCLUSIVE LEVELER LIP OPERATION

The level lip provides level loading for all heights of trailers, even when below dock loading.



2 REDUCES DAMAGE TO GOODS, PERSONNEL AND EQUIPMENT

The Flex-Lip™ levelers reduce the impact forces resulting in less personnel injury, less damage to goods while extending the life of fork and pallet truck components.

4 MODEL ADF FLEX-LIP™ AIR-POWERED LEVELER

The ADF air powered dock leveler with patented 'Next Generation Air™' technology.

5 MODEL SHF HYDRAULIC POWERED LEVELER

Features include a heavy-duty lift cylinder, totally enclosed power unit and smooth transition rear hinge.

6 FLEX BARRIER SERIES

The exclusive Flex-Barrier™ lip that provides a stay-put lip prevents accidental fall off of dock

NORDOCK® MECHANICAL DOCK LEVELERS



PROVEN PERFORMANCE ON THE LOADING DOCK

Nordock® INDUSTRIAL™ and HEAVY-METAL™ Series mechanical dock levelers are the ultimate in strength, ease of use and reliability. The full yielding easy walk down lip extension, dual pawl center position holddown for precise level storage, easy clean out subframe, 33% dual beam to deck weld pattern, zinc plated full width hinge rods, below dock end load control are all standard value added features.

KEY FEATURES

1 INDUSTRIAL™ SERIES MECHANICAL LEVELER

The INDUSTRIAL™ series mechanical levelers come with standard features including additional center deck beam, separate lip and deck maintenance struts with lockout ability, and comes with 20-Year front and rear hinge warranty. Available in up to 60,000 lb. capacity.

2 PATENTED LIP LUG AND HEADER PLATE

The deck plate, lip plate, beam sections and lugs are constructed of minimum 50-55,000 PSI yield material.

3 FULL WIDTH REAR HINGE

The continuous rear hinge provides 4" of side to side tilt with no pinch point.

4 HEAVY-METAL™ MECHANICAL LEVELER

The HEAVY-METAL™ series mechanical dock leveler is designed to provide unbeatable service in facilities where strength and reliability is a major criteria. Available in capacities up to 40,000 lbs.

Nordock® Loading Dock Systems

EDGE MOUNT DOCK LEVELERS



EZ-DOCK™ SERIES LEVELER

The EZ-Dock™ Series hydraulic powered dock levelers are the smart choice for those who prefer or cannot build a conventional recessed pit in their building. The surface mounted hydraulic design with push button activation provides a safe ergonomic alternative with more service range than edge of dock levelers.

KEY FEATURES

1 PUSH BUTTON™ EH SERIES DOCK LEVELER

The EH series hydraulic dock leveler is available in capacities up to 30,000 lb. and includes push button activation, molded bumpers and full width rear hinge.

2 LEVER™ SERIES EM MANUAL DOCK LEVELER

The EM Series is available in capacities up to 50,000 lbs. and includes molded bumpers, lever activated lip extension and auto return to dock.

3 PUSH BUTTON™ SERIES - EFH HYDRAULIC DOCK LEVELER

Available in capacities up to 80,000 lbs. with single push button activation with auto return to dock. Shown with optional steel face bumpers.

NORDOCK® CONSTRUCTOR™ SERIES DOCK LEVELERS



CA AIRDOCK® SERIES

A convenient, affordable and environmentally conscious solution with performance in mind. This leveler is powered by low pressure air and patented lifting system and is controlled by a push of a button.



CH Hydraulic Series

With push button efficiency this dock leveler delivers the ergonomic solution with patented dual function hydraulics and less parts than any other dock leveler.



CM Mechanical Series

Designed for the construction industry, this dock leveler is affordable yet designed to provide strength and reliability while outperforming other mechanicals in its class with many value added features included as standard.

Nordock® Loading Dock Systems

TECHNICAL SPECIFICATIONS

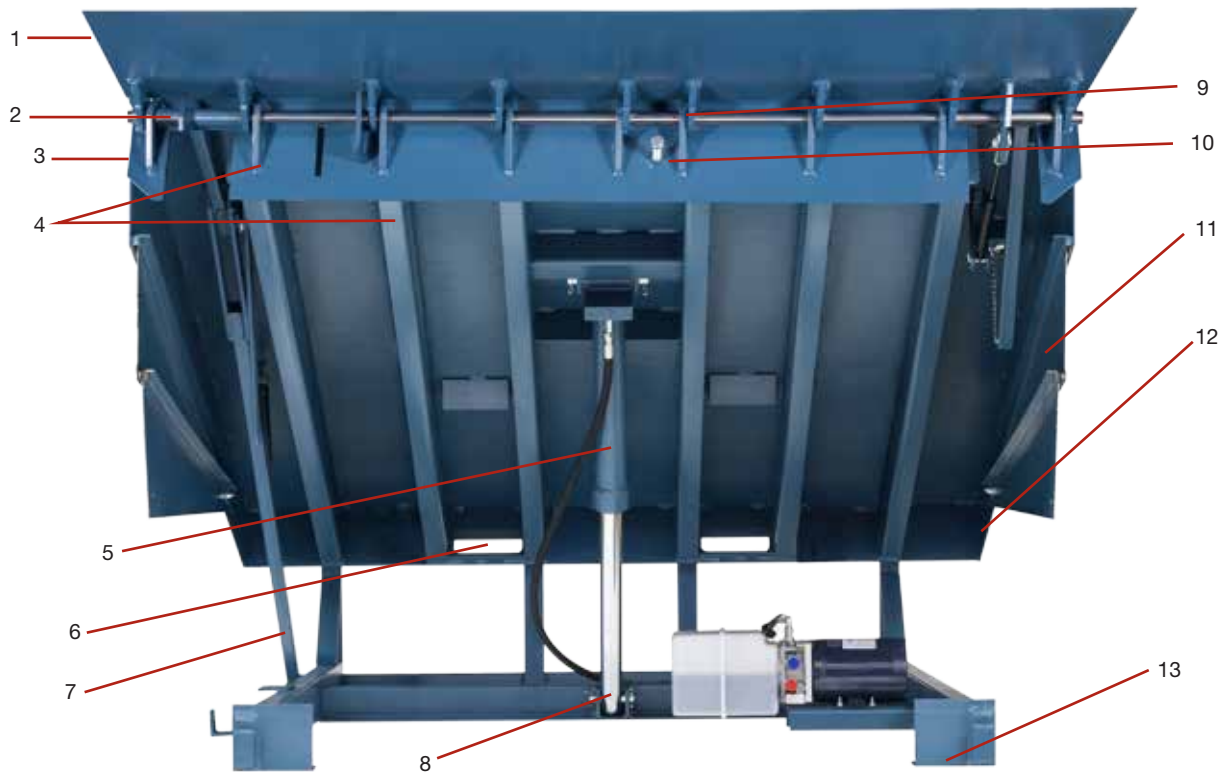

- | | |
|--|---|
| <ul style="list-style-type: none"> 1. Capacities from 9,000kg to 22,000kg
Super Duty up to 73,000kg 2. Self cleaning lip hinge 3. 10 year structural warranty
20 year warranty on Nordock-exclusive Lip Lug and front header plate 4. Unitised welded platform structure with continuous welds at the beam, header plate and lugs
Separate integral deck and lip maintenance struts (not visible)
Centre deck support for three wheel forklifts (not visible)
Centre deck support for three wheel forklifts (not visible) 5. Regenerative hydraulic cylinders with polished chrome rods, guide bearings and high pressure seals 6. Rear pockets for easy forklift movement 7. 7 solid steel supports for rear hinge | <ul style="list-style-type: none"> 8. Heavy duty cylinders with non adjustable velocity fuse 9. Zinc plated hinge rods at front and rear. Hinge factory coated with anti-seize lubricant 10. Dual-sided weld pattern on channels and lugs for added strength 11. Full range telescoping side guards 12. 20 year warranty on continuous plano style rear hinge (no visible) 13. Night locks for secure dock and support for cross-traffic <p>Barrier lip model available</p> |
|--|---|



Continuous rear hinge with seven solid steel frame supports



Nordock exclusive lip lug and header plate

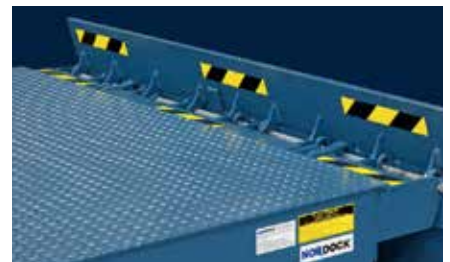

Barrier lip

Nordock® Loading Dock Systems

OTHER PRODUCTS

A wide range of Seals and Shelters are available to provide superior sealing and long term durability.

Nordock® Dock Seals & Shelters features the exclusive WearTough™ fabric with double lock stitching and reinforcements on primary wear surfaces.



RF RETRACTABLE FRAME DOCK SHELTER

The versatile RETRACTA-FRAME™ shelter is built to yield when hit by an off centre trailer preventing shelter and dock wall damage



Get more information of on Nordock® Dock Seals and Shelters from your Sales Consultant.

EVALUATE YOUR DOCK LEVELER NEEDS

Safety should be your priority when selecting your dock leveler system. For optimum productivity, select a system that's easy to operate, matches your specific needs and is reliable & durable. You should also look into maintenance costs and after-sales support from your vendor.

Selection criteria for the right leveler;

- **Dock Leveler Capacity**

Consider not just the Static Capacity required, but take into account the Dynamic Capacity, the range of motion such as the speed and frequency of use while the forklift is travelling across the leveler during use. Determine what is the gross load weight by combining the weight of your heaviest capacity lift truck plus the weight of the heaviest load to select the proper lever capacity.

Inadequate capacity can affect the life expectancy of your dock leveller and structural failures.

- **Dock Leveler Width & Length**

Please contact us for more details on selecting the right models to suit your operations needs.



Nordock® has the capability to design and manufacture engineered products for loading dock equipment including dock levelers, vehicle restraints, scissor lifts, truck levelers, dock seals and a comprehensive line of accessories. Nordock® is based out of United States and Canada. Dexion is the exclusive distributor for Nordock® complete range of products in South East Asia, China, Australia and New Zealand.

Contact

For more information on Nordock® Loading Dock Systems, please contact us on 1800 100 050.

Disclaimer:

The Information contained herein is the intellectual property of Dexion. The Information is defined to include: data, text, images, specification, graphics, design details and any and all other information whatsoever contained herein. The Information has been produced exclusively for Dexion and may not be used for any other purpose. None of the information may be used, altered, edited, copied, distributed or duplicated in any way without the express written consent of Dexion. Whilst the utmost care is taken to ensure the accuracy of the information contained herein, Dexion makes no guarantee as to its accuracy. Dexion shall, under no circumstances, be liable for any costs, losses, expenses or damage which may in any way be attributable to the use or adoption of such data and/or design details. All dimensions indicated are nominal only. Dexion reserves the right to alter or amend any of the information herein, including data and design details, without prior notice.